

Stylohyoid and posterior digastric measurement with intramuscular EMG, submental EMG and swallowing sound.

Adrien Mialland¹ ^a, Ihab Atallah² and Agnès Bonvilain¹

¹Univ. Grenoble Alpes, CNRS, Grenoble INP, Gipsa-Lab, 3800 Grenoble, France

²Otorhinolaryngology, CHU Grenoble Alpes, 38700 La tronche, France
adrien.mialland@grenoble-inp.fr

Keywords: Stylohyoid, Digastric, Electromyography, Swallowing Sound, Implantable Active Artificial Larynx.

Abstract: The stylohyoid and the posterior digastric muscles have essentially been measured through indirect imaging method because of the difficulty to measure them. They are small neck muscles, close to each other, that cannot easily be accessed independently. Yet, they showed promising results for a *robust* and *safe* indwelling detection of swallowing, both in terms of timing and recruitment. The possibility to thoroughly establish their relevance through their direct functional analysis would enable the development of an implantable active artificial larynx, that would protect the airway during swallowing detection. Therefore, we set up the first standardized procedure that allows their direct measurement through intramuscular electromyography (EMG) and that we report in this paper. We also used submental surface EMG and swallowing sound modalities to access the major time points of the swallowing process. Finally, various exercises, along with swallowing, were performed by the volunteers. 16 peoples were measured with our new procedure, and both the stylohyoid and the posterior digastric could be measured independently with no difficulty. Timings and tasks comparison are therefore ongoing.

1 INTRODUCTION

The past decades have provided detailed descriptions of the swallowing mechanism, its anatomical structures and their complex interplay (Shaw and Martino, 2013). But swallowing studies still tend to mostly report on muscles activity during swallowing tasks only, most likely because of the need to better understand the swallowing process for a clinical practice. However, this does not allow to draw conclusions in a broader perspective to get an extensive picture of muscles timing and recruitment, with regard to various tasks. Besides, the available measurement methods limit the possibilities. The neck muscles are usually small and close to each other, and the traditional surface electromyography (EMG) approach may lead to measurements that contain unwanted contamination from adjacent muscles (cross-talk). Therefore, several muscles got little attention because of the difficulty to measure them independently (Steele, 2015). Yet, we aim at the feasibility of an implantable active artificial larynx through the real-time, robust and safe indwelling detection of swallowing, which needs

high quality signals. This would be beneficial in the context of laryngeal removal, known as total laryngectomy, that requires the trachea to be sewn on the anterior neck, to create a tracheostomy. Indeed, as the laryngeal functions are lost, breathing can only be safely performed through an isolated tract. But it adds several adverse effects and the air no longer passes through the nose and the mouth anymore, which allowed filtration, warming, humidification, olfaction and acceleration of the air for better tissue oxygenation (Maclean et al., 2009). Therefore, these functions could be restored if the trachea could be set back in place and protected with an active closure mechanism, during swallowing. This requires the development of a robust and real-time swallowing detection strategy, based on muscles that activate early, provide stable and dedicated activation pattern, and are not altered by the surgery.

In that regard, we focused on the stylohyoid and the posterior digastric muscles that showed indirect but appropriate results. Indeed, few studies hint toward their importance. First, on animals the stylohyoid have been shown to activate at the beginning of the swallowing, at the same time than the submental muscles (German et al., 2009). On humans, imag-

^a  <https://orcid.org/0000-0001-5359-674X>

ing methods confirmed these results (Okada et al., 2013) and the analysis of their anatomical structure revealed a significant potential to move the larynx (Pearson et al., 2011), but direct functional data are lacking. Second, both muscles were studied as a whole *STH-PD* complex, which was shown to mainly activate during swallowing and jaw opening (Kurt et al., 2006). The authors also studied their nerve conduction in comparison to the mylohyoid, which is part of the submental muscles. They argued that "*electrophysiological identification factors may make easier to work on STH-PD muscles*". In addition, contractile patterns from animals showed a repeatable and stable activity of the stylohyoid (Thexton et al., 2012). Third, these muscles are both directly accessible during the surgery, with no further impairment required. Alternatively, other muscle could have been considered for a robust and safe detection of swallowing, but several uncertainties mitigate their interest. The mylohyoid is part of the submental muscles and demonstrates the greatest potential in laryngeal superior movements (Pearson et al., 2011). But it is also part of the floor of the mouth and activate for various tasks, to support the tongue. Also, infrahyoid muscles are easily accessible during the surgery but could be removed with the larynx, and may exhibit a large range of activation for various tasks (German et al., 2009). Finally, the pharyngeal muscles are either impaired during the surgery or would require to place the sensors deep inside the neck, and therefore to further damage the remaining functional anatomy (Lippert et al., 2016).

Besides, the swallowing process have been characterized through various methods that give access to the major events. In particular, the submental muscles are acknowledged to lead the reflexive part of swallowing and their activation assists the tongue in the propulsion of the bolus posteriorly (Park et al., 2017). These muscles are commonly measured through surface electromyography and are considered mostly free of contamination from adjacent muscles (cross-talk) (McKeown et al., 2002). Also, the forces applied to the bolus produce various sound components that are linked to bolus locations and anatomical events. Especially, the passage of the bolus through the upper esophageal sphincter (UES) generates a specific burst and is the only sound component to be found 100% of the time (Morinière et al., 2008). Recently, the beginning of that event has been suggested to be linked to the closure of the laryngeal vestibule (Kurosu et al., 2019), which protects the airway from bolus aspiration. Therefore, these two measurement methods would allow to correlate the stylohyoid and posterior digastric muscles activity with key swallowing events.

So, this paper intends to describe the measurement protocol we set up to enable the evaluation of the stylohyoid and the posterior digastric muscles with intramuscular EMG. Submental surface EMG and swallowing sound measurement methods were also used to respectively access the beginning of the swallowing and the moment the bolus goes through the UES.

2 MATERIALS AND METHODS

2.1 Subjects

Twelve healthy adults (8 males/ 8 females) with no history of dysphagia, neck surgery, immune deficiency or any neurological impairment participated in this study. The mean age was $36.1 \pm 13,6$ and all enrolled participant met the following inclusion criteria: age of 18 years or higher and a body mass index (BMI) of 25 or lower. Participants with BMI higher than 25 were intentionally excluded from this study to avoid a potentially excessive amount of fat in the region of the neck that would make the proper placement of the sensors more complex. Each participant received a detailed explanation of the study and were made aware of their rights, including the possibility to withdraw at any time. Each participant returned a written informed consent prior to the participation. Each participant underwent a standardized examination conducted by a registered otolaryngologist to confirm the absence of any sign of dysphagia. Each participant were anonymized and no identifying information were collected. All participant accomplished the full protocol. This study was approved by the research ethics committee of Sud-Méditerranée III of Nîmes in France (Protocol ID: 38RC22.0096). This study has been carried out in accordance with the Declaration of Helsinki of the World Medical Association revised in 2013 for experiments involving humans.

2.2 Sensors Placement

Prior to the sensor placement, the beard must be shaved, and the neck area must be cleared from any jewelry and clothing items that could interfere. During any sensor placement, the participant was asked for any discomfort and a swallowing was performed to confirm the absence of pain. The participants were asked to comfortably sit on a chair and each sensors were placed (Figure 2) in the following order:

SWALLOWING SOUND: The cricoid cartilage was first located by the otolaryngologist and the accelerometer was placed at its center, as it was sug-

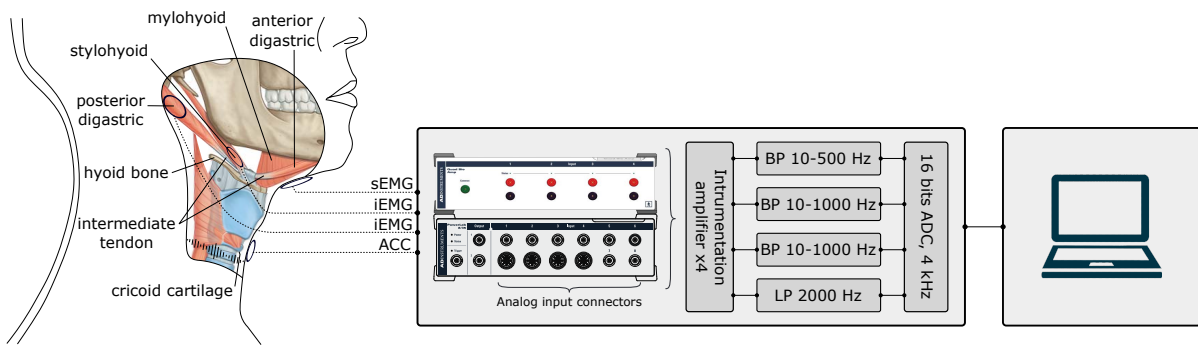

Figure 1: Sensors locations, anatomical structures and acquisition setup. EMG: electromyography, sEMG: surface EMG, iEMG: intramuscular EMG, ACC: accelerometer, BP: band-pass, LP: low-pass. ADC: analogue digital converter. The targeted anatomical regions are shown with ellipses for each sensors. 1 needle is inserted in the stylohyoid at the level of the lesser horn of the hyoid bone, next to the intermediate tendon which do not generate myoelectric signal. 1 needle is inserted in the posterior digastric, where it separates from the stylohyoid. 1 surface EMG measures the submental muscles activity. 1 accelerometer measures the swallowing sound from the top of cricoid cartilage. Each signals are then passed through an instrumentation amplifier, band-pass filtered and digitized at $4kHz$ by a 16 bits ADC, before being sent to the laptop.

gested to act as a resonator for the sound (Takahashi et al., 1994; Cichero and Murdoch, 2002). The accelerometer was fixed with a hypoallergenic paper tape, so as to record anterior-posterior vibrations. The length of the tape was chosen so as to span the neck horizontally from one lateral side to the opposite side. The tension was adjusted to get a clear event when a swallowing is performed.

SURFACE EMG: The 2 differential electrodes were placed under the left part of the submental area, with their center approximately $2cm$ apart, and the ground electrode was placed over the right clavicle. Both areas were first cleaned with a dedicated abrasive and conductive paste to reduce the electrode-skin impedance.

INTRAMUSCULAR EMG: Both the stylohyoid and the posterior digastric muscles are directly accessible behind the skin, but are close to each other. To isolate their activity, they are targeted close to their origin and insertion points: the stylohyoid muscle was targeted next to its insertion point, at the level of the junction between the body and the greater horn of the hyoid bone. This point could be identified by palpation of the lesser horn of the hyoid, which is attached by its base to the angle formed by the junction between the body and greater horn. The EMG needle punctures the skin perpendicularly at the insertion point of the stylohyoid bone and then directed upward and backward. The posterior digastric muscle was targeted in its posterior portion, next to its origin from the mastoid notch. The EMG needle is inserted perpendicularly behind the vertical ramus of the mandible and in front of the anterior border of the sternocleidomastoid muscle. It is then directed upward, medially and backward. The anatomical regions of both the site of puncture are located through

palpation and were marked on the skin before insertion. Besides, while the otolaryngologist was slowly inserting the needles, a second trained operator monitored the EMG activity on the computer to look for muscle activities. It could be requested to the participant to swallow to elicit an event. Once an event were visible on the signal, the needles were no further inserted. They were then secured with a Steri-Strip so that they cannot come out of the muscles.

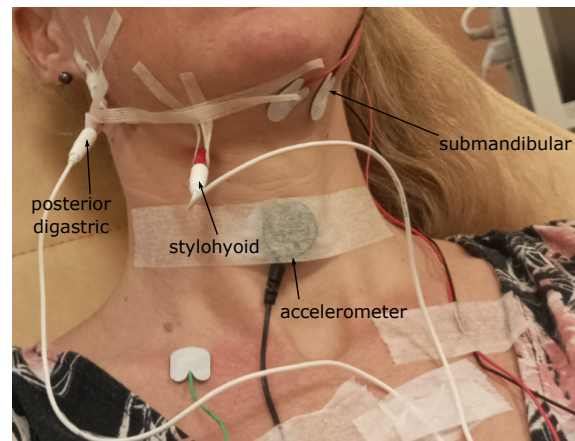

Figure 2: Sensor placement. The stylohyoid and the posterior digastric muscles are measured with intramuscular EMG, the submental muscles with surface EMG, and the swallowing sound with an accelerometer. The needles are secured with steri strips so that they cannot come out.

2.3 Signal Acquisition

From each participant 4 signals were recorded: 2 intramuscular EMG with concentric needle electrodes (27-gauge, 30 mm), 1 surface EMG with 3 surface gel

electrodes (2 differential and one ground), and 1 swallowing sound signal with an single axis accelerometer (Pulse Transducer TN1012/ST, 1600Hz, ADInstrument). The 3 EMG signals were fed to a Bio-Amp (FE234, 4 channels, ADInstrument) pre-Amplifier with differential inputs, which is in turn connected to a PowerLab (35 series, 4 channels, ADInstrument) data acquisition system. The accelerometer were directly connected to the PowerLab with a built-in dedicated connector. On the computer, the LabChart ADInstrument data acquisition and analysis software receives the signals from the PowerLab. This set up allows to have all 4 signals synchronized in time. Then, the Bio-Amp filters the 2 intramuscular EMG signals with a 10 – 1000Hz analogue band-pass filter and the surface EMG signal with a 10 – 500Hz analogue band-pass filter. The swallowing sound signal is also filtered, with a 2000Hz low-pass analogue filters. Finally, each channel uses a 16 bits analogue-digital-converter (ADC) and all signals were sampled at 4000Hz, which simplified the file format and allowed down-sampling if required.

2.4 Protocol

Both swallowing and non-swallowing tasks were performed by participants. The task is first prepared by asking the participant to take the bolus into the mouth and/or to adopt a relaxed position. Then, the signal acquisition is launched and 2 second with no motion is recorded. The participant is then asked to perform the task and 2 more second with no motion are acquired. This ensure to record a clear event. Also, when a task is performed, the keyboard is pressed to place a marker on the event, which facilitates its location in post-processing.

SWALLOWING TASKS: Participants were asked to perform 5 swallowing of Saliva, water (10ml), thick liquid (compote) and solid bolus (madeleine).

NON-SWALLOWING TASKS: Participant were asked to perform (1) 3 times mouth opening, lips purseing, teeth clenching, smiling, whistling, coughing, blowing through a straw, counting from 1 to 10, saying "iii" in ascending and descending order. (2) 3 times movement tasks being jaw movements, lateral head movements and head extension and flexion. They are performed in neutral - right - left - neutral or neutral - extension - flexion - neutral order depending on the task. (3) 5 times chewing, that are actually recorded at the moment the solid bolus swallowing tasks is performed. To separate the two, the participant is asked to hold the bolus in the mouth once chewed, ready to swallow, before being asked to swallow it. All tasks are performed to a comfortable full

extent and at a natural pace.

2.5 Signal Processing

Offline analysis was performed with a custom piece of software. A 2nd order high-pass Butterworth digital filters with a cut-off frequencies of 20Hz is applied on the EMG signals and a 4th order Butterworth notch filters is applied to all signals to eliminate the 50Hz line noise. The baselines are then delineated to include 1 second of recording that contains no event of any sort. Next, all signals are transformed using the Teager-Kaiser energy operator (TKEO) $\Psi[x(n)] = x(n)^2 - x(n-1)x(n+1)$, which has been shown to improve the SNR (Li et al., 2007). Then, the following are extracted:

MUSCLE ONSET/OFFSET: We used a method based on generalized likelihood ratio (GLR) (Xu et al., 2013). Using a 200ms sliding window of size n samples, it continuously computes the likelihood ratio of a contracted muscle state hypothesis H_1 against a relaxed muscle state hypothesis H_0 . This allows to estimate the time instant r of muscle onset and offset, based on a series of observations $y_0^n = [y(0), \dots, y(n)]$ from the current window. A probability density function (PDF) $P_1(y(t))$ and $P_0(y(t))$ is associated with each hypothesis, and the likelihood that y_0^n is drawn from one of these PDF is expressed in Equation 1.

$$L_i(y_0^n) = p_i(y_0^n) = \prod_{t=0}^n P_i(y(t)) \quad (1)$$

Where i is the type of hypothesis. The likelihood ratio is then expressed in Equation 2.

$$\frac{L_1(r, y_0^n)}{L_0(y_0^n)} = \frac{p_0(y_0^{r-1})p_1(y_r^n)}{p_0(y_0^n)} = \prod_{t=r}^n \frac{P_1(y(t))}{P_0(y(t))} \quad (2)$$

Where $L_1(r, y_0^n)$ is the likelihood that y_0^n is drawn from both PDF, with H_1 starting from time instant r . The likelihood ratio is then maximize over the possible transition time r of the current window. Therefore, this requires to know the distribution followed by the data and we opted for an exponential PDF. Indeed, on the basis of empirical evidences, it closely represents the TKEO transformed EMG, as long as its absolute value is considered, which is in line with recent investigations (Selvan et al., 2018). An adaptive Threshold is then applied and is chosen to be 10% of the maximum current GLR values. The onset and offset are then located manually according to the threshold, to avoid any false positive detection.

BOLUS THROUGH UES: the moment the bolus enters the UES corresponds to the major sound burst

and is suggested to be linked to the closure of the laryngeal vestibule (Kurosu et al., 2019). This allows to locate the ultimate time point where the airway must be protect. The transformation of the signal with TKEO allows to bring this event out and facilitate the manual location of its beginning.

3 Results and Discussion

The goal of this paper was to describe the protocol we set up that made feasible the measurement and the evaluation of the stylohyoid and the posterior digastric muscles. Very few studies focused on those muscles and none enabled the investigation of both their timing and contraction patterns.

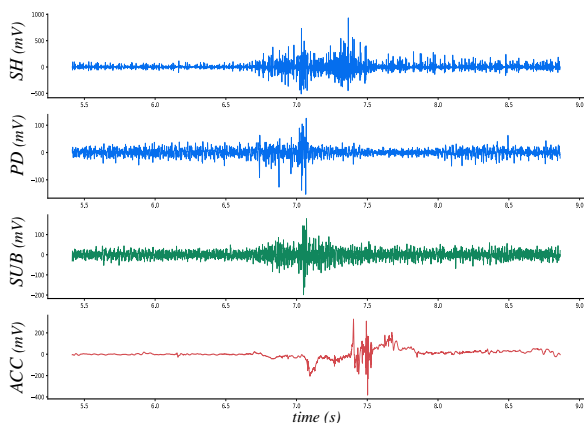

Figure 3: Raw signals of a saliva swallowing. SH: stylohyoid, PD: posterior digastric, SUB: submental, ACC: accelerometer. All signals provide distinguishable events. The burst of higher frequency in the ACC signal corresponds to the moment where the bolus goes through the upper esophageal sphincter.

The challenging aspect of our protocol is the proper placement of the concentric needles, to record the stylohyoid and the posterior digastric muscles separately. Even though concentric needles are very selective, both muscles are thin and close to each other, which may lead to the wrong muscle to be measured. Therefore, we chose to target the stylohyoid close to its insertion point, at the level of the lesser horn of the hyoid bones. In that region, the posterior digastric is composed of its intermediate tendon, which cannot produce EMG signal and therefore cannot be mistaken for the stylohyoid EMG signal. Besides, the posterior digastric muscle was targeted close to its origin at the level of the mastoid notch. In that region, it separates from the stylohyoid, which originates from the styloid process upper in the neck. In addition, these anatomical regions were found through palpa-

tion, and the decision to exclude the participants with a BMI upper than 25 limited the amount of fat and allowed to find them with no difficulty. Finally, these muscles are the first to be accessible behind the skin. Once an activity were visible on the screen, the needle were not inserted any further and were secured with steri strips. The needles were, therefore, fixed in depth but could follow the anatomical movement. The present paper therefore provide the first standardized procedure that allows to measure both the stylohyoid and the posterior digastric muscles independently. In the past, only one study provided direct functional analysis of those muscle through intramuscular EMG (Kurt et al., 2006), but they were only measured as a whole *STH-PD* complex, with no possibility to differentiate their activity, both in terms of timing and recruitment. Also, the authors mainly focused on nerve conduction and did not directly seek to evaluate their timing. We therefore expend those points with our new procedure, which provide independent signals.

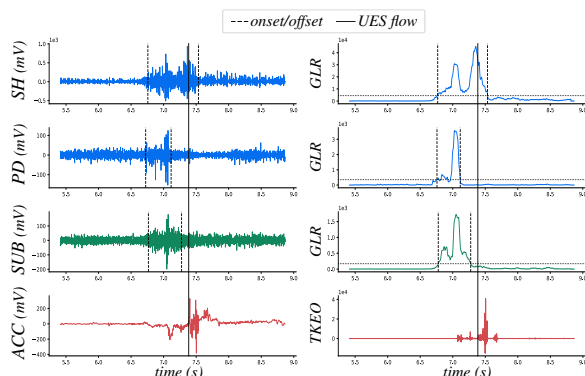

Figure 4: signal processing results. Left: raw signals. Right: processed signals. Dashed lines: onset and offset. Solid lines: the moment when the bolus goes through the upper esophageal sphincter (UES). The dashed lines locations are found with the generalized likelihood ratio (GLR) method, applied on the EMG (top 3) signals. The solid line location is found with the Teager-Kaiser energy operator (TKEO), applied on the accelerometer (bottom) signal.

With regard to the swallowing sound, we focused on its major component. Early investigation of that event showed its rise in frequency content compared to the rest of the signal (Hamlet et al., 1990). The authors suggested that this was the result of the increase in pressure generated by the contraction of the surrounding muscles that forces the bolus through the UES. More recently, modern data analysis methods confirmed the particular frequency content of that event (Lee et al., 2008) and formerly linked its occurrence with the bolus that passes through the UES (Morinière et al., 2008). This event was also the only one to occur 100% of the time. Finally, the begin-

ning of that event is suggested to be temporal linked to the closure of the laryngeal vestibule (Kurosu et al., 2019). This later event is of prime interest to define the ultimate moment when the airway are physiologically required to be closed. This would in turn define the timing for an active closure mechanism to be closed as well. Therefore, the use of TKEO is justified by its ability to highlight the high frequency contents, and were particularly effective in this study (Figure 4). However, one may argue about the lack of bandwidth analysis of the swallowing sounds. Indeed, only its upper limits have been investigated and no recommendation allows to formerly delineate a particular sound component. Yet, these considerations usually arise when it comes to the precise analysis of the swallowing process. But the main UES sound component clearly stands out and the TKEO essentially magnifies its frequency content. Besides, the swallowing sound modality allows to avoid the use of videofluoroscopy, which requires X-ray exposure. Therefore, these elements make the swallowing sound and the TKEO operator, an effective and safe combination to define the ultimate closing time, from the perspective of an implantable active artificial larynx. The related time marker were then set manually with no difficulty and is visible Figure 4.

Besides, we looked for an semi-automated muscle activity segmentation to reliably determine their onset and offset points. But the literature provides a wide range of algorithm and none has shown to be effective for all the various bio-mechanical application that uses EMG (Tenan et al., 2017). So, we used the GLR for its ability to modelize the signals and therefore its robustness to various background noise (Xu et al., 2013). As an example, intramuscular EMG requires the insertion of a needle inside the muscles throughout the whole acquisition. The presence of this invasive foreign body may cause the reflexive contraction of relatively few muscle fibers, which can be visible on the signal as spurious background spikes (Figure 3). Besides, it allows to adapt to the channel being analyzed so that every muscle activity are compared on the same basis, which limits possible biases.

Finally, the various tasks performed by the participants allowed to access a large range of every day contraction pattern. However, this obviously does not represent free-living signals because we seek to formerly characterize the stylohyoid and the posterior digastric, with regard to the criteria described section 1. Therefore, each tasks were performed with no additional motion to get a clear event on the signals. First sight on the data confirmed the literature on the activation of the stylohyoid and the posterior digastric during swallowing. Further analysis are currently car-

ried out to provide extensive results.

4 CONCLUSION

Very few studies focused on the functional analysis of the stylohyoid and the posterior digastric muscle because of their location. Also, none sought to formerly characterize both their timings and contraction patterns in various tasks, including swallowing. Yet, those muscles showed promising results for the development of an implantable active artificial larynx, through the *robust* and *safe* real-time detection of swallowing. Therefore, to formerly evaluate their potential independently, we described in this paper the precise acquisition protocol that we set up with the use of intramuscular EMG, submental surface EMG and swallowing sound measurement methods. Intramuscular EMG were used to obtain the activity of both the stylohyoid and the posterior digastric independently, with the insertion of the needles following the localization of precise anatomical structure. In addition, submental surface EMG and swallowing sound allowed to locate the beginning of the swallowing and the moment the bolus passes through the upper esophageal sphincter, respectively. All these modalities give access to various key swallowing events for a comprehensive characterization. 16 people underwent the full procedure and the volunteers were asked to perform a large variety of activity, along with swallowing, to evaluation the recruitment specificity of the stylohyoid and the posterior digastric muscles. Besides, timing investigation requires the localization of onset and offset of muscle activity and we proposed the use of a generalized likelihood ratio approach. It allowed to effectively abstract from background noise, following the modelisation of baseline and muscle activities. This paper therefore allowed us to access specific swallowing signals, to investigate the potential utility of both the stylohyoid and posterior digastric muscles in the real-time detection of swallowing. Further work are on-going to provide extensive characterization.

ACKNOWLEDGMENTS

This research has been carried out with funding from the Région Auvergne Rhône Alpes.

REFERENCES

- Cichero, J. A. and Murdoch, B. E. (2002). Detection of Swallowing Sounds: Methodology Revisited. *Dysphagia*, pages 40–49.
- German, R. Z., Crompton, A. W., and Thexton, A. J. (2009). Integration of the Reflex Pharyngeal Swallow Into Rhythmic Oral Activity in a Neurologically Intact Pig Model. *Journal of Neurophysiology*, pages 1017–1025.
- Hamlet, S. L., Nelson, R. J., and Patterson, R. L. (1990). Interpreting the Sounds of Swallowing: Fluid Flow through the Cricopharynx. *Annals of Otology, Rhinology & Laryngology*, 99:749–752.
- Kurosu, A., Coyle, J. L., Dudik, J. M., and Sejdic, E. (2019). Detection of Swallow Kinematic Events From Acoustic High-Resolution Cervical Auscultation Signals in Patients With Stroke. *Archives of Physical Medicine and Rehabilitation*, pages 501–508.
- Kurt, T., Gürgör, N., Seçil, Y., Yıldız, N., and Ertekin, C. (2006). Electrophysiologic identification and evaluation of stylohyoid and posterior digastric muscle complex. *Journal of Electromyography and Kinesiology*, 16:58–65.
- Lee, J., Steele, C. M., and Chau, T. (2008). Time and time–frequency characterization of dual-axis swallowing accelerometry signals. *Physiological Measurement*, page 1105.
- Li, X., Zhou, P., and Aruin, A. S. (2007). Teager–Kaiser Energy Operation of Surface EMG Improves Muscle Activity Onset Detection. *Annals of Biomedical Engineering*, pages 1532–1538.
- Lippert, D., Hoffman, M. R., Britt, C. J., Jones, C. A., Hernandez, J., Ciucci, M. R., and McCulloch, T. M. (2016). Preliminary Evaluation of Functional Swallow After Total Laryngectomy Using High-Resolution Manometry. *Annals of Otology, Rhinology & Laryngology*, 125:541–549.
- Maclean, J., Cotton, S., and Perry, A. (2009). Post-Laryngectomy: It’s Hard to Swallow. *Dysphagia*, pages 172–179.
- McKeown, M. J., Torpey, D. C., and Gehm, W. C. (2002). Non-invasive monitoring of functionally distinct muscle activations during swallowing. *Clinical Neurophysiology*, pages 354–366.
- Morinière, S., Boiron, M., Alison, D., Makris, P., and Beutter, P. (2008). Origin of the Sound Components During Pharyngeal Swallowing in Normal Subjects. *Dysphagia*, pages 267–273.
- Okada, T., Aoyagi, Y., Inamoto, Y., Saitoh, E., Kagaya, H., Shibata, S., Ota, K., and Ueda, K. (2013). Dynamic change in hyoid muscle length associated with trajectory of hyoid bone during swallowing: analysis using 320-row area detector computed tomography. *Journal of Applied Physiology*, pages 1138–1145.
- Park, D., Lee, H. H., Lee, S. T., Oh, Y., Lee, J. C., Nam, K. W., and Ryu, J. S. (2017). Normal contractile algorithm of swallowing related muscles revealed by needle EMG and its comparison to videofluoroscopic swallowing study and high resolution manometry studies: A preliminary study. *Journal of Electromyography and Kinesiology*, pages 81–89.
- Pearson, W. G., Langmore, S. E., and Zumwalt, A. C. (2011). Evaluating the Structural Properties of Suprahyoid Muscles and their Potential for Moving the Hyoid. *Dysphagia*, pages 345–351.
- Selvan, S. E., Allexandre, D., Amato, U., and Yue, G. H. (2018). Unsupervised Stochastic Strategies for Robust Detection of Muscle Activation Onsets in Surface Electromyogram. *IEEE Transactions on Neural Systems and Rehabilitation Engineering*, 26:1279–1291.
- Shaw, S. M. and Martino, R. (2013). The Normal Swallow: Muscular and Neurophysiological Control. *Otolaryngologic Clinics of North America*, pages 937–956.
- Steele, C. M. (2015). The Blind Scientists and the Elephant of Swallowing: A Review of Instrumental Perspectives on Swallowing Physiology. *Journal of Texture Studies*, pages 122–137.
- Takahashi, K., Groher, M. E., and Michi, K.-i. (1994). Methodology for detecting swallowing sounds. *Dysphagia*, pages 54–62.
- Tenan, M. S., Tweedell, A. J., and Haynes, C. A. (2017). Analysis of statistical and standard algorithms for detecting muscle onset with surface electromyography. *PLOS ONE*, page e0177312.
- Thexton, A. J., Crompton, A. W., and German, R. Z. (2012). EMG activity in hyoid muscles during pig suckling. *Journal of Applied Physiology*, pages 1512–1519.
- Xu, Q., Quan, Y., Yang, L., and He, J. (2013). An Adaptive Algorithm for the Determination of the Onset and Offset of Muscle Contraction by EMG Signal Processing. *IEEE Transactions on Neural Systems and Rehabilitation Engineering*, pages 65–73.